



RatioMatic Burners

Model RM075

Version 3.10

Main Specifications - RM075

PARAMETER	SPECIFICATIONS				
Maximum input (Btu/hr) Note: Contact factory for varying chamber pressures or pressures outside the range: -2.0" to 2.0" w.c. (-5.0 to 5.0 mbar)	Frequency	BTU/hr	"w.c.	kW	mbar
	60 Hz Packaged Blower	1,070,000	-2.0	313	-5.0
		990,000	-1.0	290	-2.5
		900,000	0.0	263	0.0
		800,000	1.0	234	2.5
		680,000	2.0	199	5.0
	50 Hz Packaged Blower	1,070,000	-2.0	313	-5.0
		990,000	-1.0	290	-2.5
		900,000	0.0	263	0.0
		800,000	1.0	234	2.5
680,000		2.0	199	5.0	
Minimum input			BTU/hr	kW	
• with high turndown ratio regulator			30,000	9	
• with standard ratio regulator			40,000	12	
Main Gas Inlet Pressure			" w.c.	mbar	
• Fuel pressure at ratio regulator inlet			10 to 20	25 to 50	
High Fire Flame Length			inches	mm	
• Measured from the outlet end of combustor	Natural gas	30		762	
	Propane / Butane	36		914	
Maximum Chamber Temperature			° F	° C	
	Alloy Tube	1500		820	
	SiC Tube	1900		1040	
Flame Detection	Flame rod or UV scanner				
Fuel	Natural gas, Propane, or Butane. For any other mixed gas, contact Eclipse Combustion for orifice sizing				

- All information is based on laboratory testing. Different chamber size and conditions will affect the data.
- Maximum inputs are given for the standard combustion air blower without an air filter.
- All inputs based upon gross calorific values and standard conditions; 1 atmosphere, 70° F (21°C).
- Eclipse reserves the right to change the construction and/or configuration of our products at any time without being obliged to adjust earlier supplies accordingly.

Performance Graphs RatioMatic RM075

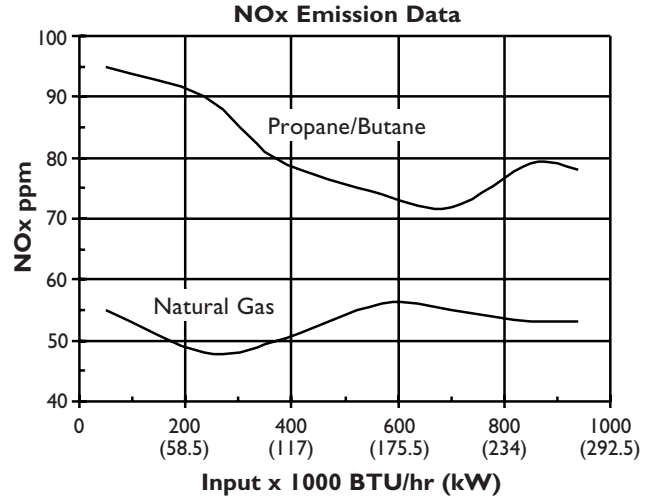
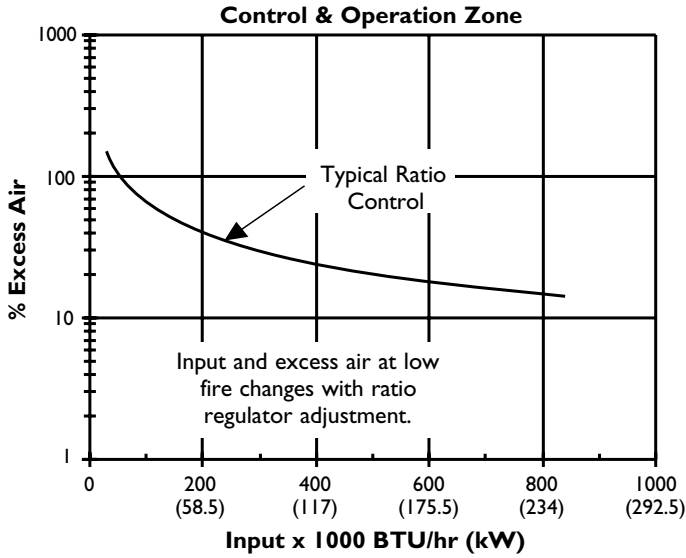

NOx emission data is given for:

- Ambient combustion air ~70 F (20 C)
- Less than 700 F (370 C) firing chamber
- Minimal process air velocity
- Low fire input adjusted to 40,000 BTU/hr (12kW)
- ppm volume, dry @ 3% O₂
- Neutral chamber pressure

Emissions are influenced by:

- Chamber conditions
- Fuel type
- Firing rate
- Ratio regulator adjustment
- Combustion air temperature

CO emission is largely influenced by chamber conditions. Contact your local Eclipse Combustion representative for an estimate of CO emission on your application

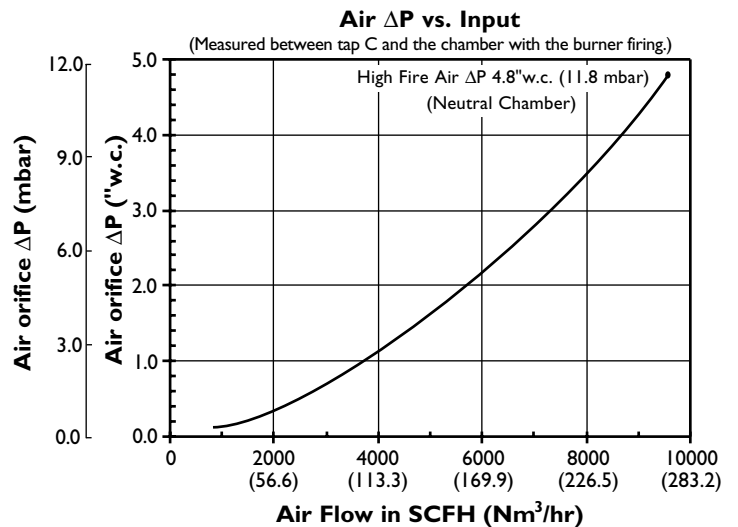
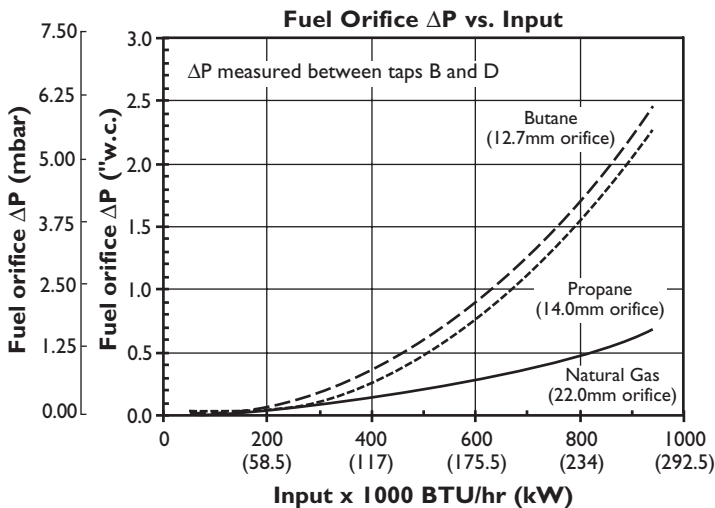

Dimensions-RM075

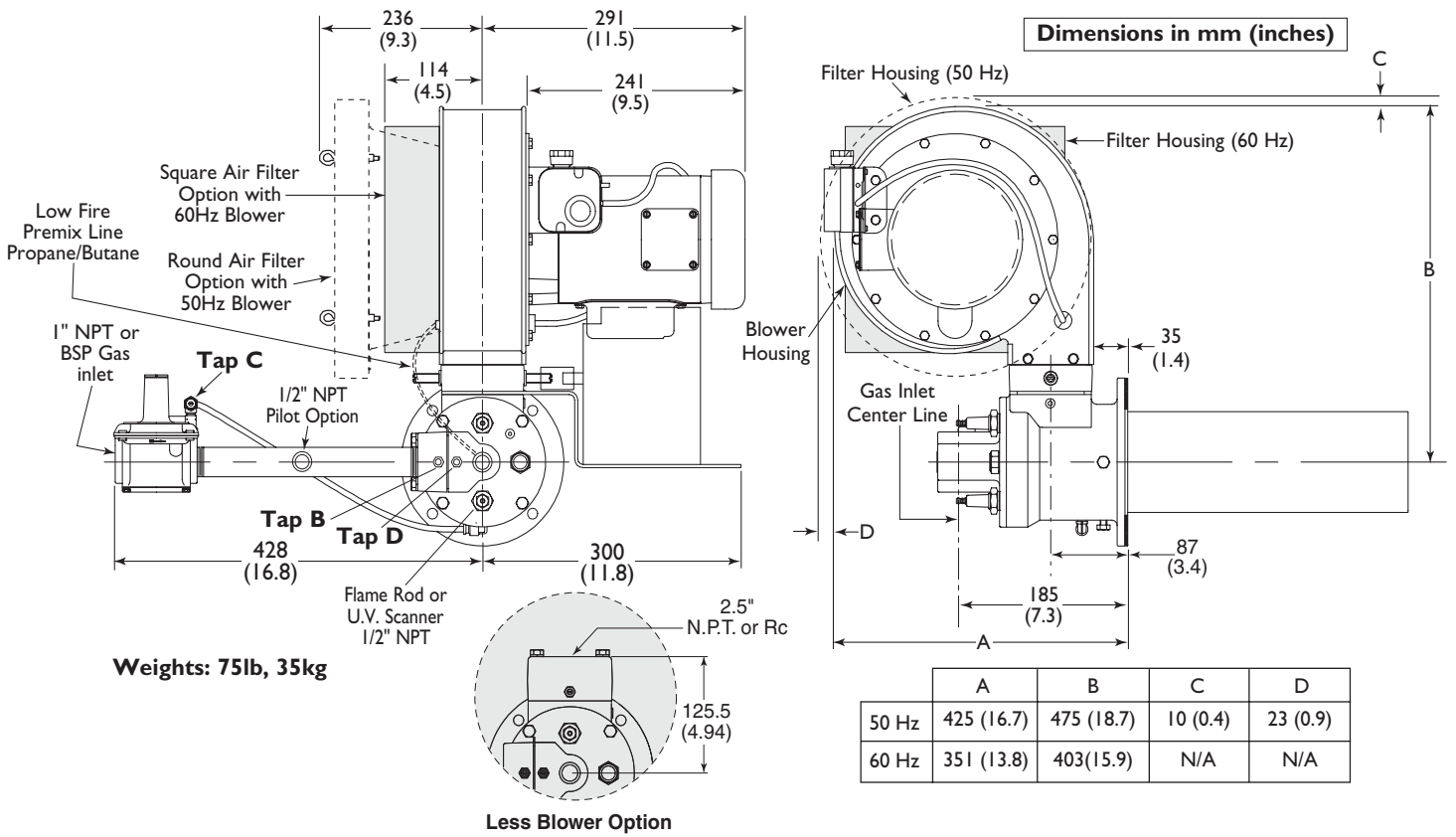

Combustor types

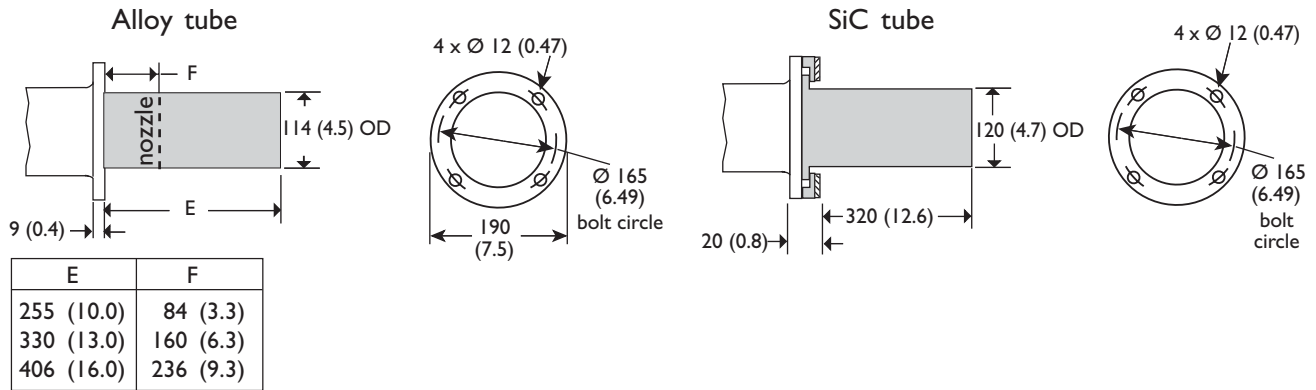

Burner configuration

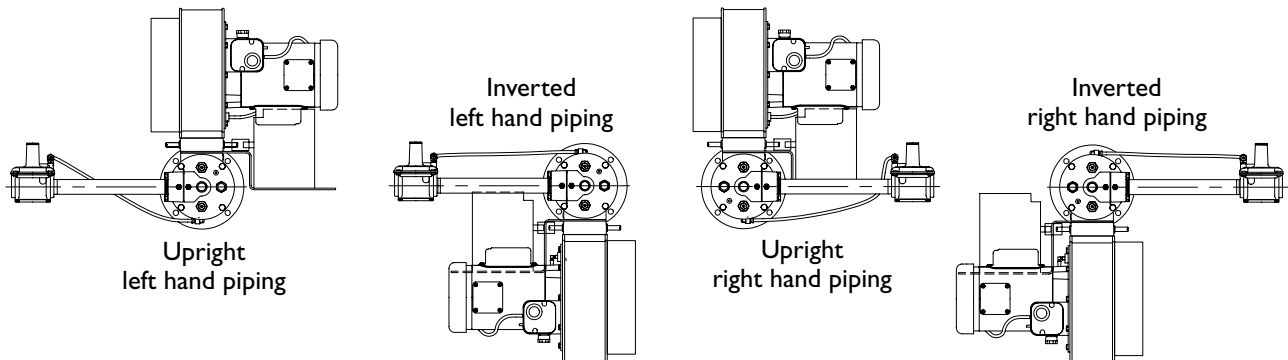



Offered By:

Power Equipment Company
2011 Williamsburg Road
Richmond, Virginia 23231
Phone (804) 236-3800
Fax (804) 236-3882

www.peconet.com